

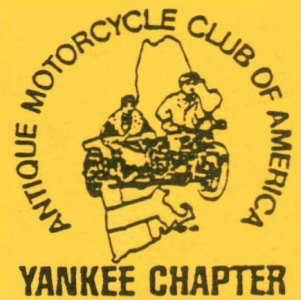

YANKEE CHATTER



AUTUMN 1990

No. 90-4

YANKEE CHAPTER ANTIQUE MOTORCYCLE CLUB OF AMERICA, INC.

Chapter Established in 1972

HAPPINESS is an
Antique Motorcycle!

Trophy winners at YANKEE Chapter's Acton, Maine Meet on June 23-24, 1990 discuss the merits of Ed Morinho's 1937 INDIAN Four while standing by for the photographer. Look who's playing expert!

*both photos by
Tom "Torch" Neill*



"Doc" Patt told us that judging could be a rewarding experience, and lots of fun—but he didn't say it would be THIS funny!

Marty Hansen, Mike Hebert and Dave Howland judging a winner.

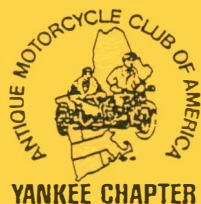

Officers

	<u>ZIP Code</u>	<u>Telephone</u>	<u>Term of office expires</u>
Co-Director - Jessie A. Jacaruso			December 1991
Co-Director - James A. Costa			December 1991
Vice Director - Martin Hansen			December 1991
Vice Director - Andrew J. Connor			December 1991
Vice Director - James E. Darby, Jr.			December 1991
Secretary - Virginia M. Adams			December 1991
Treasurer - Frederick D. Hirsch			December 1991
National Director - George L. Yarocki			September 1990
Editor/Publisher - Frederick D. Hirsch			December 1991



YANKEE CHATTER

AUTUMN 1990 No. 90-4

CONTENTS

Advertisements - Acton Meet Buttons	11
Swap Meet - Stafford Springs, Connecticut, October 28, 1990	15
YANKEE PEDLAR	15
Co-Director's Message	3
Editor's Notes	
Tom Swift and His Motor-Cycle	4
Edward A. Higgins	4
Miscellaneous	
Cork Display Board	10, 11
Other Chapter Logos and Insignia	2, 15
"That's Not My Job"	14
TOM SWIFT and His Motor-Cycle	8, 9
YANKEE CHAPTER	
Acton, Maine Meet photos	Front Cover
Bentley, Earl V. - Obituary	2
Business Meeting/Christmas Party - December 2, 1990 - Announcement	7
Membership Roster - 1990	12, 13, 14
Officers	2
Sturbridge, Massachusetts Meet - Report of Winners	3
Treasury Reports - for June 27, 1990 (after Acton)	4
for September 10, 1990 (after Sturbridge)	5
for September 23, 1990 (after Keene)	6

Total Distribution = 211 * Total Membership = 185

EARL V. BENTLEY

It is our sad duty to report to our YANKEE Chapter members the death of a fellow enthusiast. Earl passed away at his home in Windsor, Connecticut on August 15, 1990 after a long illness, just a few days before the EMPIRE Chapter's Brookfield, New York NATIONAL Meet, and only a few days before two of his vintage hill-climbing machines were to go on public exhibition at the AMA Heritage Museum in Westerville, Ohio.

He was a long-time YANKEE Chapter member and rarely missed attending Chapter activities. His trophy-winning restorations were almost too good for such a dirty sport, but they added much glamor to the antique motorcycling scene.

Some more Chapter logos and insignias

More on page 15.



(BADGER HERITAGE)

 YANKEE CHATTER is the official newsletter of the YANKEE Chapter of the Antique Motorcycle Club of America, and is published four times each year on a seasonal basis: WINTER, SPRING, SUMMER and AUTUMN. The YANKEE Chapter of the AMC of A was established April 8, 1973. Dues for the 1990 membership year are \$ 10.00 single; \$ 12.50 with spouse. Membership is not transferable and dues are not refundable.

Applicants wishing to join the YANKEE Chapter must FIRST be members in good standing (paid up) of the National AMC of A; however, applicants may apply for both memberships to the Chapter Treasurer at any time, and memberships received after October 31st of any year will be held over for the next membership year. National AMC of A membership dues for the 1990 membership year are \$ 20.00 single; \$ 25.00 with spouse. A \$ 1.00 service charge is made for handling an applicant's National application.

Distribution of YANKEE CHATTER is to members of record in good standing (paid up), officers and directors of the AMC of A, and certain editors and other officers of the AMC of A Chapters. As a member of the National AMC of A, YANKEE Chapter is a non-profit organization.

Co-Director's Message

*

We were lucky enough to be able to wrap up our season with a beautiful weekend at Sturbridge, Massachusetts on September 8th and 9th; and by a rough count 36+ YANKEE Chapter members were noted to be in attendance at Wray Murdough's great Flea Market in Keene, New Hampshire on September 23rd.

At Sturbridge there were 14 vendors on Saturday and the flea market activity was steady. Unfortunately, many people left in the afternoon and only 35 of us remained for the banquet. "Andy" Anderson came well prepared with two birthday cakes so that we could celebrate his 85th birthday!

Sunday morning Tim and Dick Downs scouted the local area byways and mapped out a route for a road run. While they were busy with this activity, Andrea Downs was appointed as Chief Judge with Maureen Hansen and Linda Casey as her assistants.

The girls judged 23 machines starting with Frank Adams' 1915 INDIAN twin and Ray Bellefleur's 1915 HARLEY-DAVIDSON and others ranging up through John Pierce's 1955 HARLEY-DAVIDSON FLH. See categories and judging results at right.

When the judging was completed, 11 machines with riders and passengers went out on the 10-mile road run. How the leaders ever found it I don't know, but it was a beautiful and scenic ride and most enjoyable.

Our Business Meeting/CHRISTMAS Party is scheduled for December 2, 1990, which is the first Sunday of the month. At that time the Officers will fill you in on details of our 1991 NATIONAL Meet which is approved and scheduled for August 3-4, 1991 to be held at the fairgrounds in Bethlehem, Connecticut, which is in the western part of that State and only 15 miles, as the crow flies, from the New York State line.

PLEASE NOTE: The CHRISTMAS Party will be held at a NEW location! See map and instructions on page 7, which were supplied by our YANKEE Chapter member Alex Olearos.



Jessie A. Jacaruso
Co-Director

WINNERS at

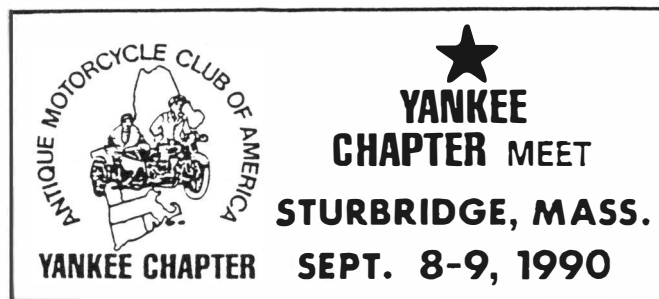

This year we decided to add a little variety to our judging categories, and we also appointed three of our lady members to do the judging. Results and awards follow:

Judges: Andrea Downs
Linda Casey
Maureen Hansen

°

MOST UNIQUE

George Twine - 1918 EXCELSIOR w/sidecar

DIRTIEST MOTORCYCLE

Dan Vine - 1947 INDIAN w/sidecar

RUSTIEST MOTORCYCLE

Frank Adams - 1915 INDIAN Twin

LOUDEST MOTORCYCLE

Fred Hirsch - 1954 BSA B-33

CUTEST POWERCYCLE

Jack Kowal - 1946 Model "H" WHIZZER on
1957 COLUMBIA bicycle

OLDEST MOTORCYCLE

Frank Adams - 1915 INDIAN Twin

LONGEST DISTANCE RIDDEN

John Pierce - 1955 HARLEY-DAVIDSON FLH
120 miles

MOST ORIGINAL

Mike Jacaruso - 1933 HARLEY-DAVIDSON
Model RL 45 c.i.

PRETTIEST RESTORATION

Larry Wood - 1921 HENDERSON 4-cylinder

LADIES' CHOICE - Best of Show

Larry Wood - 1921 HENDERSON 4-cylinder

°

METEOROLOGIST [Weatherman]

A guy who looks in a girl's eye to see whether.

Editor's Notes

and Other . . .

TOM SWIFT and His Motor-Cycle

The story included in this issue is taken from a boyhood book owned by YANKEE CHATTER'S Editor; and as will be noted dates back a few decades—like six-and-a-half plus! It was always a favorite and is still a cherished childhood memory. I did not get involved with motorcycles until after I emerged with a whole skin from the AUS [Army of the United States—not to be confused with USA (which is United States Army, also known as the Regular Army). Got that? The AUS was composed of drafted civilians taken into service because of the 'emergency'; whereas USA soldiers were enlistees, not conscripts—but, I digress. . . and that is another story.

Tom Swift, in case you didn't already know or suspect it, was the son of an inventor and was himself a youthful inventor. What else? Victor Appleton was writing stories about young hero types which appealed to kids who were born before the advent of radio, "The Green Hornet", "The Shadow", "Jack Armstrong", or "Suspense Theatre"—our big escape from reality was our youthful imaginations and our books of juvenile heroes and their derring-do deeds which sold for as much as 75¢ a copy! We also had Saturday afternoons at the local movie theatre for the next episode of "The Perils of Pauline", "Phantom of the Opera", or best of all a cliff-hanger western starring Tom Mix or William S. Hart (Hopalong Cassidy) when the price of admission was 10¢ (that's ten cents!).

Many of my friends had other books of the Tom Swift series and we swapped and loaned them back and forth. I recall many a night taking my trusty flashlight to bed with me so I could read the latest thriller under the covers when my bedroom light dare not be lit because of parental reprimand; and I'm sure that my friends and I, and others like us, helped keep the EVEREADY Battery Company in business throughout the early years of the Great Depression.

*

EDWARD A. HIGGINS

Ed's death on July 11, 1990 was duly recorded in "The ANTIQUE MOTORCYCLE" for Fall 1990, and since all Chapter members receive this NATIONAL magazine, I will only mention that I knew Ed for about 12 years through our association with the AMC of A and especially through the EMPIRE Chapter, of which he was a founding member.

For several years we were both house guests at the home of Al Cecchini in New York while in attendance at the EMPIRE Chapter's early Spring meet, and Saturday evening talks about motorcycles often ran into the wee hours.

He had a dry sense of humor and I commented more than once that he would have made a good New England YANKEE of the Calvin Coolidge type. He referred to jet airplanes as 'kerosene kites' and the State of Georgia was always "Jaw-Jaw".

He was a good friend and I shall miss him. During his lifetime he was able to do the things that he wanted to do. What more can anyone ask?

*



TREASURY REPORT - September 24, 1990

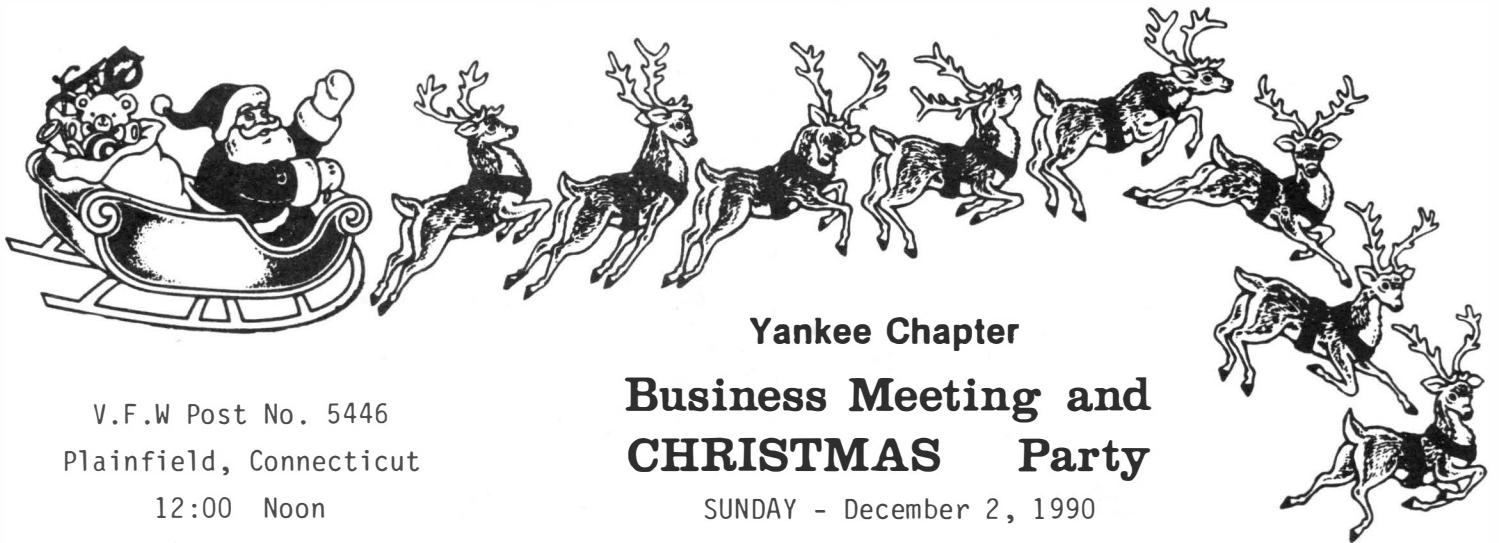

V.F.W Post No. 5446
 Plainfield, Connecticut
 12:00 Noon



HOW to Get There

From NORTH or SOUTH on I-395: [1] Proceed to EXIT 88; take off ramp to Connecticut Route 14A and go WEST on Connecticut Route 14A for 1/2 mile to STOP Sign. [2] Go LEFT (South toward Norwich) on Connecticut Route 12 for 1/2 mile to traffic signal and turn RIGHT on Railroad Avenue (this is still Connecticut Route 14A). Proceed to bottom of hill and turn RIGHT on Windsor Avenue; go approximately 300 yards to V.F.W. Post No. 5446 parking lot.

From WEST on Connecticut Route 14A (Willimantic and Canterbury): Proceed to Plainfield center on Railroad Avenue. Turn LEFT on Windsor Avenue and go approximately 300 yards to V.F.W Post No. 5446 parking lot.

From EAST on Connecticut Route 14A (R.I.State line): Proceed to STOP Sign at Connecticut Route 12; then proceed as in [2] above for NORTH or SOUTH.

If you get lost the telephone number at the V.F.W. Post is (203) 564-8022.

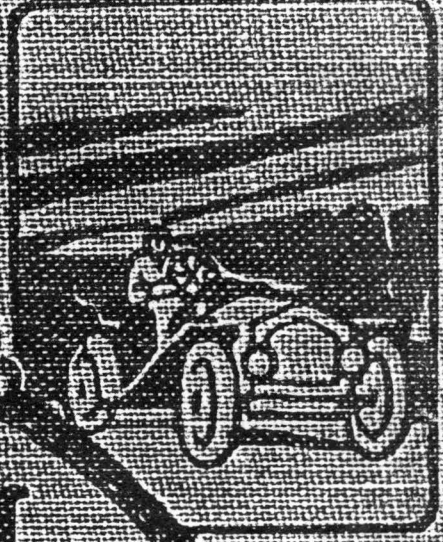

**TOM
SWIFT
AND HIS
MOTOR-CYCLE**

**VICTOR
APPLETON**





This larger-than-life facsimile is from the cover of a boyhood book entitled "TOM SWIFT and His Motor-Cycle". It was written by Victor Appleton and published by Grosset & DunTop, New York, N. Y. in 1910, long before the appearance of most YANKEE Chapter members!

The following extracts are from pages of the book detailing an experience which Tom had and his amazing solution! He was on an errand for his Father and along the way encountered a tramp on the road. The tramp is talking:

"What's your name, anyhow, cully?"

"Tom Swift," replied our hero, and again he wished he had not told. This time he was sure the tramp started and glanced at him quickly, but perhaps it was only his imagination.

"Tom Swift," repeated the man musingly, and his tones were different from the whining ones in which he had asked for money.

He turned away, and Tom was beginning to breathe more easily when the ragged man, with a quick gesture, reached out and grabbed hold of the motor-cycle. He gave it such a pull that it was nearly torn from Tom's grasp. The lad was so startled at the sudden exhibition of vindictiveness on the part of the tramp that he did not know what to do. Then, before he could recover himself, the tramp darted into the bushes.

"I guess Happy Harry—dat's me—has spoiled your ride t' Albany!" the tramp cried.

*

Tom wheeled his motor-cycle to a hard side-path along the old road, and jumped into the saddle. He worked the pedals preparatory to turning on the gasolene and spark to set the motor in motion. As he threw forward the levers, having acquired what he thought was the necessary momentum, he was surprised that no explosion followed. The motor seemed "dead."

"That's queer," he thought, and he began to pedal more rapidly. "It always used to start easily. "Maybe it doesn't like this sandy road."

It was hard work sending the heavy machine along by "leg-power," and once more, when he had acquired what he thought was sufficient speed, Tom turned on the power. But no explosions followed, and in some alarm he jumped to the ground.

"Something's wrong," he said aloud. "That tramp must have damaged the machine when he yanked it so." Tom went quickly over the different parts. It did not take him long to discover what the trouble was. One of the wires, leading from the batteries to the motor, which wire served to carry the current of electricity that exploded the mixture of air and gasolene, was missing. It had been broken off close to the battery box and the spark plug.

"That's what Happy Harry did!" exclaimed Tom. "He pulled that wire off when he yanked my machine.

*

The young inventor looked up and down the lonely road, undecided what to do. To return home meant that he would be delayed in getting to Albany, for he would lose a day. If he pushed on to Pompsville he might be able to get a bit of wire there.

Tom decided that was his best plan, and plodded on through the thick sand. It was hard work pushing the heavy machine through the sand, and he was puffing before he had gone very far.

"I certainly am up against it," he murmured. "But if I can get a bit of wire in Pompsville I'll be all right. If I can't—"

Just then Tom saw something which caused him to utter an exclamation of delight.

"That's the very thing!" he cried. "Why didn't I think of it before?"

Leaving his motor-cycle standing against a tree Tom hurried to a fence that separated the road from a field. The fence was a barbed-wire one, and in a moment Tom had found a broken strand.

"Guess no one will care if I take a piece of this," he reasoned. "It will answer until I can get more. I'll have it in place in a jiffy!"

It did not take long to get his pliers from his toolbag and snip off a piece of the wire. Untwisting it he took out the sharp barbs, and then was ready to attach it to the binding posts of the battery box and the spark plug.

"Hold on, though!" he exclaimed as he paused in the work. "It's got to be insulated, or it will vibrate against the metal of the machine and short circuit. I have it! My handkerchief! I s'pose Mrs. Baggert* will kick at tearing up a good one, but I can't help it."

Tom took a spare handkerchief from the bundle in which he had a few belongings carried with the idea of spending the night at an Albany hotel, and he was soon wrapping strips of linen around the wire, tying them with pieces of string.

"There!" he exclaimed at length. "That's insulated good enough, I guess. Now to fasten it on and start."

The young inventor, who was quick with tools, soon had the improvised wire in place. He tested the spark and found that it was almost as good as when the regular copper conductor was in place. Then, having taken a spare bit of the barbed-wire along in case of another emergency, he jumped on the motor-cycle, pedaled it until sufficient speed was attained, and turned on the power.

"That's the stuff!" he cried as the welcome explosions sounded. "I guess I've fooled Happy Harry! I'll get to Albany pretty nearly on time, anyhow. But that tramp surely had me worried for a while."

He rode into Pompsville, and on inquiring in a plumbing shop managed to get a bit of copper wire that answered better than did the galvanized piece from the fence. The readjustment was quickly made, and he was on his way again.

* - Mrs. Baggert is Tom's Father's housekeeper.

THE O.D. YANKEE WORKSHOP

(With apologies to Norm Abrams)

Cork Display Board

By Kevin Meyers

How about a simple project, for around ten dollars, that will greatly enhance the presentation of your MC at the next rally or other static display?

Well, here are all the assembly drawings and materials you will need. An added benefit is that, with a display, the public may get the hint that your pride and joy is something other than a carnival ride for the kids to climb on and destroy.

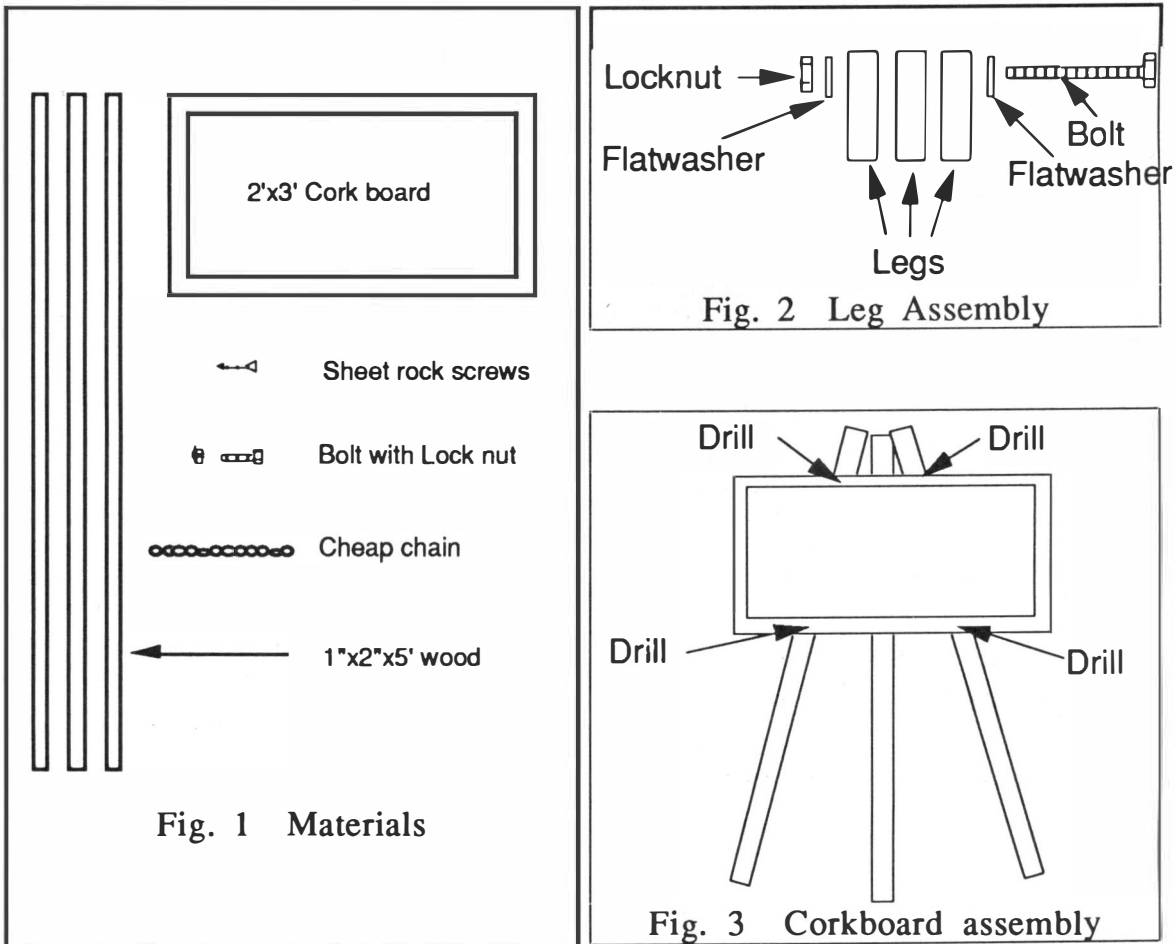

Cork Display Board

Step 1 Cut the three pieces of 1"x2" (the legs) to five feet long. A clearance hole for the bolt is needed on one end of each of the three pieces of 1"x2". This hole must be one nominal size larger than the bolt used. For example if a 1/4" bolt is used, drill the holes 5/16" in diameter. Drill the holes for the bolt one inch from the top and one inch from the side through the two inch side.

Step 2 The bolt must be three and a half to four inches long to allow the legs (the 1"x2" pieces) to spread. Join the three pieces of 1"x 2" with the bolt. Although, not necessary I recommend using two flat washers, one on each side of the stacked legs. Turn the locknut on flush with the end of the bolt. See Figure 2.

Step 3 Lay the legs on a flat working surface. Spread the outer legs. Now, lay the corkboard on top of the legs. Align the corkboard about three inches from the top and centered. Drill a pilot hole for the sheet rock screws through the top and bottom edges of the corkboard to each of the outer legs. This will keep the wood from splitting. See Figure 3. Screw the corkboard to the legs.

Step 4 Attach the chain to the three legs and paint or whatever. Your display board is now ready for a write up on your vehicle or pictures of your vehicle before restoration or pictures of similar vehicles in use, etc.

ACTON MEET BUTTONS are still available - in case you missed out, or didn't get a chance to attend. Blue with Black printing. \$ 1.50 each POSTPAID. Order from Fred Hirsch, P. O. Box 123, Carolina, R. I. 02812.

IMPORTANT NOTICE

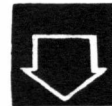

ALL ads listed in YANKEE PEDLAR expire with this issue. The FREE advertising privilege extended to all AMC of A members is conditional upon renewal of membership. Ads will not be repeated automatically - members in good standing must submit NEW requests and NEW copy for the 1991 issues.

Editor

Shown
FULL
SIZE



Membership Roster



1990

CONNECTICUT

Albert, Walter H.	Mansfield Center	Connecticut	06250
Anderson, Andy	Willington	Connecticut	06279
Ashwell, James	Abington	Connecticut	06230
Bellefleur, Ray	Darien	Connecticut	06820
Colella, LeRoy & Jacqueline M.	Bristol	Connecticut	06010
Currey, Richard F.	Stafford Springs	Connecticut	06076
Connor, Andrew J. & Christine Lees	Norwich	Connecticut	06360
Darby, Jr., James E.	Rockville	Connecticut	06066
Delor, Arthur G. & Linda M.	Waterford	Connecticut	06385
Downs, Richard	Washington Depot	Connecticut	06794
Downs, Timothy & Andrea	Falls Village	Connecticut	06031
Funk, III, Charles E.	Coventry	Connecticut	06238
Gallo, Charles A. & Sandra W.	Mansfield Center	Connecticut	06250
Gazza, Al	East Glastonbury	Connecticut	06025
Greski, Lee	Suffield	Connecticut	06078
Griswold, Donald E. & Ruth A.	Avon	Connecticut	06001
Hansen, Martin & Maureen	Manchester	Connecticut	06040
Hinze, David K. & Regina Chiarella	South Lyme	Connecticut	06376
Leighton, James L.	Talcottville	Connecticut	06066
Litke, Rudolph J.	Litchfield	Connecticut	06759
Lynk, Jr., Gary A.	Torrington	Connecticut	06790
McAvoy, John	Norwich	Connecticut	06360
Olearos, Jr., Alexander M.	Moosup	Connecticut	06354
Payne, Thomas L.	Dayville	Connecticut	06241
Peircey, David	Naugatuck	Connecticut	06770
Russell, David J.	Unionville	Connecticut	06085
Switter, Donald J.	Westport	Connecticut	06880
Twine, George R.	Enfield	Connecticut	06082
Vance, Daniel L. & Sandra	Stafford Springs	Connecticut	06076
Vine, Daniel	New London	Connecticut	06320
Vreeland, Paul N.	Winsted	Connecticut	06098
Wright, Thomas J.	Vernon	Connecticut	06066
Yarocki, George L.	Torrington	Connecticut	06790
Yushkevich	South Glastonbury	Connecticut	06073

DELAWARE

Green, John	Smyrna	Delaware	19977
Neill, Thomas E. & Lynda	Smyrna	Delaware	19977

MAINE

Barnes, Jr., Lowell E. & Tiffney	Hiram	Maine	04041
Beaulieu, William J.	Auburn	Maine	04210
Berube, Scott A.	Acton	Maine	04001
Chase, Robert B.	Augusta	Maine	04330
Coffin, Bruce	Brunswick	Maine	04011
Gagne, Robert T.	South Berwick	Maine	03908
Gould, Everett L.	Gardiner	Maine	04345
Gould, Jerry V.	Windsor	Maine	04363
Heath, Donald A.	South Berwick	Maine	03908
Korthy, Gabe	Portland	Maine	04103
Moulton, Joseph W.	Kittery	Maine	03904
Patrick, Chandler	South Gardiner	Maine	04359
Paul, Harvey	South Berwick	Maine	03908
Nuppula, Gerald W.	Hollis Center	Maine	04042
Peirce, Charlene M.	Brownfield	Maine	04010
Peirce, Robert A.	Brownfield	Maine	04010
Schneider, Nancy L.	Millinocket	Maine	04462
Thurlow, Dennis	North Monmouth	Maine	04265
White, Alan	Berwick	Maine	03901

MASSACHUSETTS

Ashley, Jr., Karl J.	East Freetown	Massachusetts	02717
----------------------	---------------	---------------	-------

Ashley, Scott	West Wareham	Massachusetts	02576
Berube, Michael	Swansea	Massachusetts	02777
Berube, Thelma	Charlton	Massachusetts	01507
Blessington, Scott	Georgetown	Massachusetts	01833
Bolton, Fred	Wareham	Massachusetts	02571
Campbell, William E. & Erin P.			
Carlson, Richard I.	Billerica	Massachusetts	01865
Carr, Haswell R.	Kingston	Massachusetts	02364
Casey, James W. & Linda K.	Fall River	Massachusetts	02720
Catanesye, William	Brockton	Massachusetts	02402
Connolly, David F.	Revere	Massachusetts	02151
Corvini, Bob	Watertown	Massachusetts	02172
Dardinski, Roger	Waltham	Massachusetts	02154
Dechambeau, David S.	Newburyport	Massachusetts	01950
Epstein, Mitchell G.	Gardner	Massachusetts	01440
Evers, John F. & Joan L.	Leominster	Massachusetts	01453
Fahey, Jr., George B.	Leominster	Massachusetts	01453
Felt, Keith	Natick	Massachusetts	01760
Frizzell, Stephen	Sudbury	Massachusetts	01776
Goodreau, Ted W.	Swansea	Massachusetts	02777
Goss, Darryl B.	Norton	Massachusetts	02766
Green, Leslie H. & Lynn D.	Framingham	Massachusetts	01701
Howland, David R. & Holly J. D.	Holyoke	Massachusetts	01040
Hurley, John J.			
Hurwitz, William & Janet	Dennis	Massachusetts	02638
Joseph, David M. & Barbara A.	South Easton	Massachusetts	02375
Joseph, Janice M.	Medfield	Massachusetts	02052
Kyprianos, Christopher C.			
Laferriere, Pete & Dolores L.	Brockton	Massachusetts	02401
Leonard, Bruce	Norton	Massachusetts	02766
Leukhardt, Edward G.	Gardner	Massachusetts	01440
Lingley, Michael E.			
Masuret, James F.	Sturbridge	Massachusetts	01566
Mathieu, Roger A. & Blanche H.	Acushnet	Massachusetts	02743
Meyers, Kevin J.	Greenfield	Massachusetts	01301
Murray, Paul M.	Sudbury	Massachusetts	01776
Randall, Paul	North Weymouth	Massachusetts	02191
Robertson, James			
Robertson, Thomas I.	Brimfield	Massachusetts	01010
Sharland, Richard H.	North Chelmsford	Massachusetts	01863
	Wilbraham	Massachusetts	01095
	Auburn	Massachusetts	01501
	Medford	Massachusetts	02155
	Wakefield	Massachusetts	01880
	Taunton	Massachusetts	02780
Sheldon, Nathan F.	Paxton	Massachusetts	01612
Virgin, Dennis S.	Billerica	Massachusetts	01862

NEW HAMPSHIRE

Adams, Frank E.	Seabrook	New Hampshire	03874
Aldrich, George W. & Susan J.			
Alexander, Brian E.	Tilton	New Hampshire	03276
Avery, Curt	Derby	New Hampshire	03038
Bogash, Peter	Concord	New Hampshire	03301
Buchanan, Mark P.	Seabrook	New Hampshire	03874
Carlson, William E.	Newmarket	New Hampshire	03857
Cassell, George	North Hampton	New Hampshire	03862
Cheney, George F.	Kensington	New Hampshire	03827
Currier, Richard E.	Campton	New Hampshire	03223
Dionne, Dennis J.	Londonderry	New Hampshire	03053
Hardmon, Robert	Dover	New Hampshire	03820
Hersch, Louis	Hudson	New Hampshire	03051
Huber, William	Salem	New Hampshire	03079
Hueber, Roland A.	Kingston	New Hampshire	03848
Jacarusio, Michael E.	Gilmanton	New Hampshire	03237
Jacarusio, Jessie A.	Rollinsford	New Hampshire	03869
Keating, Brian P.	Rollinsford	New Hampshire	03869
Langton, Gary P.	West Lebanon	New Hampshire	03784
LaRosa, Jr., Joseph	North Hampton	New Hampshire	03862
McGrath, Mark H.	Salem	New Hampshire	03079
Murdough, Wray	Salem	New Hampshire	03079
Parmelee, Michael	Keene	New Hampshire	03431
Pierce, John H.	Nashua	New Hampshire	03060
Sears, Herb	Barrington	New Hampshire	03825
Undercofler, Joseph & Cindy	Rochester	New Hampshire	03867
Wood, Laurier A.	Hudson	New Hampshire	03051
	Pelham	New Hampshire	03076

NEW YORK

Adams, Virginia M.	Schenectady	New York	12304
Baron, Gene	Bayshore	New York	11706
Gloucester, George E.	Selden	New York	11784
Krauer, Kenneth C.	Salt Point	New York	12578
Henken, Jonathan	Pleasantville	New York	01570
Schmidt, Jerry A.	Wappingers Falls	New York	12590

PENNSYLVANIA

Costanzo, Daniel	Cresco	Pennsylvania	18326
------------------	--------	--------------	-------

RHODE ISLAND

Anthony, Richard S. & Paula M.	Coventry	Rhode Island	02816
Costa, James A.	Harmony	Rhode Island	02829
Forgue, Randy	North Scituate	Rhode Island	02857
Galipeau, Jean R.	Tiverton	Rhode Island	02878
Geremia, Glen	Foster	Rhode Island	02825
Harrington, Tracy & Elaine C.	Wakefield	Rhode Island	02879
Hirsch, Frederick D.	Carolina	Rhode Island	02812
Luther, Russell B.	Foster	Rhode Island	02825
Nagy, Karl E & Marilyn	Coventry	Rhode Island	02816
Morinho, Edward J. & Diane Mackie	Jamestown	Rhode Island	02835
Rose, Frederick S.	North Scituate	Rhode Island	02857
Ross, David K.	East Greenwich	Rhode Island	02818
Saleeba, Thomas J.	North Scituate	Rhode Island	02857
Santopietro, Paul A. & Cynthia	Warwick	Rhode Island	02886

VERMONT

Brown, Ross A.	Burlington	Vermont	05401
Carris, Bill	Rutland	Vermont	05702
Fagan, William T.	Burlington	Vermont	05401
Haygood, John D.	St. Johnsbury	Vermont	05819
Hebert, Michael & Patricia M.	Jericho	Vermont	05465
McDonald, William E.	Milton	Vermont	05468
Pastor, Joseph G. & Patricia A.	Colchester	Vermont	05446
Scherk, David A.	Waterbury	Vermont	05676
Turner, Tom & Jeanette	Plainfield	Vermont	05667

TOTAL YANKEE Chapter Membership for 1990 =	Connecticut	34	Pennsylvania	1	Total Regulars	155
	Delaware	2	Rhode Island	14	ADD Spouse Memberships	30
	Maine	19	Vermont	9		
	Massachusetts	43			GRAND Total	185
	New Hampshire	27				
	New York	6	Total Regulars	155		

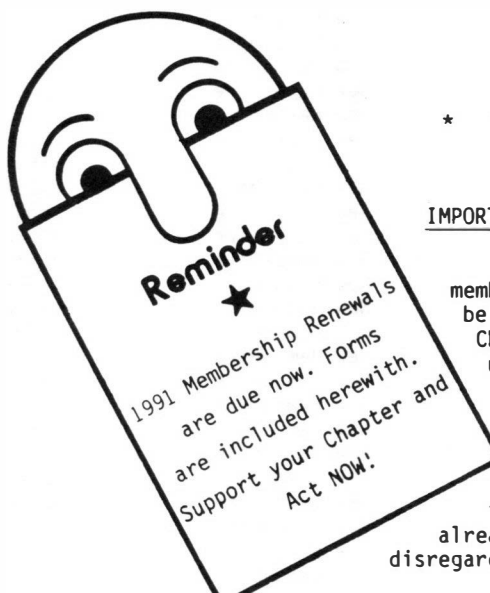

* * *

IMPORTANT NOTICE - Unless we receive your 1991 YANKEE Chapter membership dues soon, this will be the last issue of YANKEE CHATTER that you will receive until they are paid. An Application for Membership is enclosed for your convenience, so do yourself a favor and take care of this little matter before it is too late. If you have already renewed for 1991 please disregard this notice.

“THAT’S NOT MY JOB”

This is a story about four people named Everybody, Somebody, Anybody and Nobody. There was an important job to be done and Everybody was sure that Somebody would do it. Anybody could have done it, but Nobody did it. Somebody got angry about that, because it was Everybody’s job. Everybody thought Anybody could do it, but Nobody realized that Everybody wouldn’t do it. It ended up that Everybody blamed Somebody when Nobody did what Anybody could have.

YANKEE PEDLAR

Membership advertising in YANKEE PEDLAR is FREE to all YANKEE Chapter members of record (dues paid up).

DEADLINE Dates for ALL ads	WINTER Issue	January 10
	SPRING Issue	April 10
	SUMMER Issue	July 10
	AUTUMN Issue	October 15

WANTED - Information, Literature, and any Owner/Shop Manuals (copies OK) on 1957 HONDA "Dream" 345 cc single cylinder OHC (brought back by GI from Okinawa before HONDA imported to USA; also, parts bike 250-350 cc, no matter how bad. My bike runs good but needs some external parts. Also need any literature, manuals, etc., on 1974 MZ TS 250 cc. Kenneth C. Krauer, R 1 - Box 611, Clinton Hollow Road, Salt Point, New York 12578. Tel.: (914) 266-3363 - after 5:00 P.M.

WANTED - Literature, pictures, road tests (copies OK) of LUBE- NSU, SA (made in Spain mid-1960's) and SIMSON 250 OHV single shaft drive (East Germany). Desperately need anything on these two motorcycles. Simson is running. Need manuals, literature, etc. Kenneth C. Krauer, R 1 - Clinton Hollow Road, Salt Point, New York 12578. Tel.: (914) 266-3363 - after 5:00 P.M.

WANTED - A good complete battery box for a 1921 HARLEY-DAVIDSON twin, H-D tool box for top of gas tank. Andy Anderson - Tel.: (203) 429-1843.

FOR SALE - HARLEY-DAVIDSON '45' parts. for "RL" Model L: Engine cases NOS (32-35), clutch and brake pedals with side stands, frame, narrow rear brake drum; for "WL" Model L: springer front end, 17" front wheel/hub, 16" rear wheel/hub/NEW Conti tire, jiffy stand, drag pipes (new); for "G" Model L: rebuilt engine and transmission (57), gas/oil tanks. Les Green - Tel.: (413) 534-5072 after 5 PM.

WANTED - Manual and parts information for 1952 Sears ALLSTATE (Puch). Les Green - Tel.: (413) 534-5072 after 5 PM.

. . . more Chapter logos and insignias

CONNECTICUT'S ANNUAL FALL MOTORCYCLE SWAP MEET AND ANTIQUE & CUSTOM BIKE SHOW

• SUNDAY •

OCT. 28

STAFFORD^{AT} SPEEDWAY

RT. 140, STAFFORD SPRINGS, CONN.

7 AM.
to
4 P.M.

ADMISSION \$5 / VENDOR SPACES \$20.
DEALER SPACE AVAILABLE AT THE GATE.

RAIN
OR
SHINE!

FOR MORE INFORMATION
(203) 871-2776 or (203) 875-7768

MOTEL LISTING... CALL AHEAD	
• COMFORT INN - VERNON	(203) 871-2432
• COLONIAL INN - VERNON	(203) 644-1563
• HOWARD JOHNSONS - VERNON	(203) 875-0781
• QUALITY INN - VERNON	(203) 646-5700
• CONN. MOTOR LODGE - MANCHESTER	(203) 643-1555
• RED ROOF INN - ENFIELD	(203) 741-2571
• HARLEY HOTEL - ENFIELD	(203) 741-2211

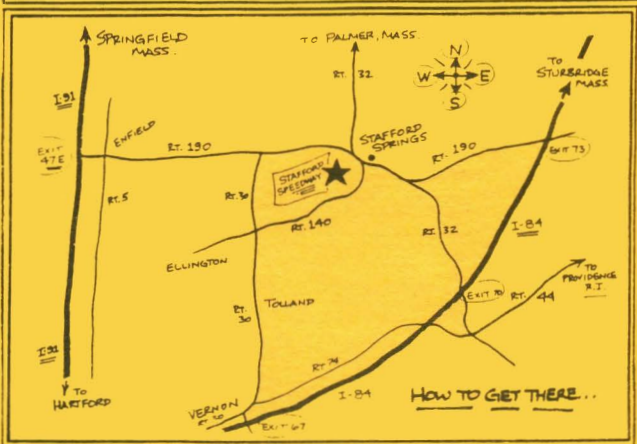

+o+o+o+



Chapter
Davenport, Iowa





YANKEE CHAPTER

Frederick D. Hirsch
P.O. Box 123
Carolina, Rhode Island



02812

FIRST CLASS MAIL

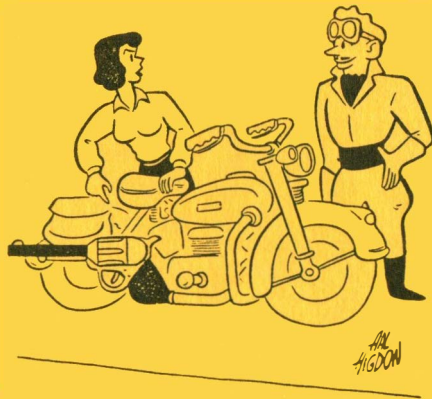

"No wonder you're always backfiring!"

