



YANKEE CHATTER



Issue 2005 / 1

Established in 1973

YANKEE CHAPTER
ANTIQUE MOTORCYCLE CLUB OF AMERICA, INC.



Diane Stoyanovich Photo

A Lovely Day For A Ride

This collection of Yankee Chapter members rode their bikes to the annual Christmas Party and business meeting at the VFW in Oxford, MA on December 5, 2004.

We Ride 'Em !

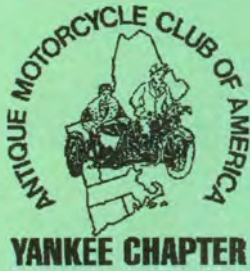

Officers

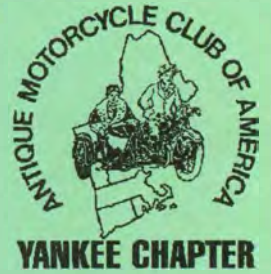

Director
Will Paley

Honored Member
Frederick D. Hirsch

Vice Director
Andrew LaRoche

Vice Director
Steve Ciccalone

Vice Director
Barbara Salisbury

Chapter Judge
Randall Walker

Treasurer
Sandra Gallo

Secretary
Diane Stoyanovich

Editor
Charles Gallo

Chapter Advisor
Jessie Aikman

Membership Chairman
Phil Mathews

Associate
Dan Margolien

Associate / Webmaster
Jim Casey

Associate
Don Salisbury

ISSUE 2005 / 1

Contents

Director's Message.....	3
Road To Recovery.....	3
Secretary's Reports.....	4-6
Yankees Out and About.....	7
Once Upon A Time.....	8
Northeast Regional Meet Ad.....	9
Yankee National Road Run Ad.....	10
Calendar.....	11

Save these dates:

Berkshire Mountains Road Run	June 19 - 22
Hebron Regional Meet	July 29 - 31
Sterling Chapter Meet	September 9 - 11

www.yankeechapter.org
is the address of the
Yankee Chapter web site.
Visit it for event details.

"Ride 'Em, Don't Hide 'Em"

YANKEE CHATTER is the official newsletter of the YANKEE Chapter of the Antique Motorcycle Club of America, and is published three times a year, when information warrants. The YANKEE Chapter of the AMC of A was established April 8, 1973. Dues for the 2005 membership year are \$10.00 individual; \$12.50 with associate member. Membership is not transferable and dues are not refundable.

Applicants wishing to join the YANKEE Chapter must FIRST be members in good standing (paid up) of the National AMC of A; however, applicants may send membership applications to the Chapter Membership Chairperson at any time, and memberships received after October 1st of any year will be held over for the next membership (calendar) year.

Distribution of YANKEE CHATTER is to members of record in good standing (paid up), officers and directors of the AMC of A, and certain editors and other officers of the AMC of A Chapters. As a member of the National AMC of A, YANKEE Chapter is a non-profit organization.



Director's Message

It's springtime in the Berkshires! I thought this winter would never end. A couple of my friends dragged me out for a ride at the end of March, and we ended up on one of the routes for our road run. The snow was still four feet deep on the sides of the road. I remember thinking, "I hope this melts before June", and felt thankful for electric jacket liners.

Now that the warmer weather has arrived, it's time for us to dust off our old bikes and get on the road. The meet in Oley, PA this month is a great way to start the season. There will be a brief meeting of Yankee officers and members at the 101/Walker Machine table on Saturday at 2:00, so I'll see some of you then. Another small, but fun meet is the Empire Chapter meet at Rhinebeck, NY on May 21 & 22. Although the idea of a regional meet has been put on the back burner, it's something that will be coming up again, so this is a good chance to look over the Fairground.

If you haven't registered for our ROAD RUN, now is a good time to do so. We have to limit the run to 250 people and it would be too bad if any of our own members couldn't fit in.

Lastly, keep in mind that we will be hosting our Chapter meets in Hebron on July 29 & 30 and Sterling on September 9 - 11, so make plans to be there.

See you on the road!

Will

Road To Recovery

Yankee Anthony Rutledge is finally back at home following a five week hospitalization for a drug resistant bacterial pneumonia. He is expected to make a full recovery. We look forward to seeing Anthony on the road again soon. Drop him a line at:

Anthony Rutledge
718 Main Street North
Southbury, CT 06488

Ed Lingley, son of Yankee Mike Lingley, is at Walter Reed Medical Center, being treated for very serious shrapnel wounds which he received while serving our country in Iraq. As Americans, we send him our thanks and our prayers for a speedy recovery. You can write to him at:

Attention: Spc. Ed Lingley
Ward 68
6900 Georgia Avenue NW
Washington, DC 20307

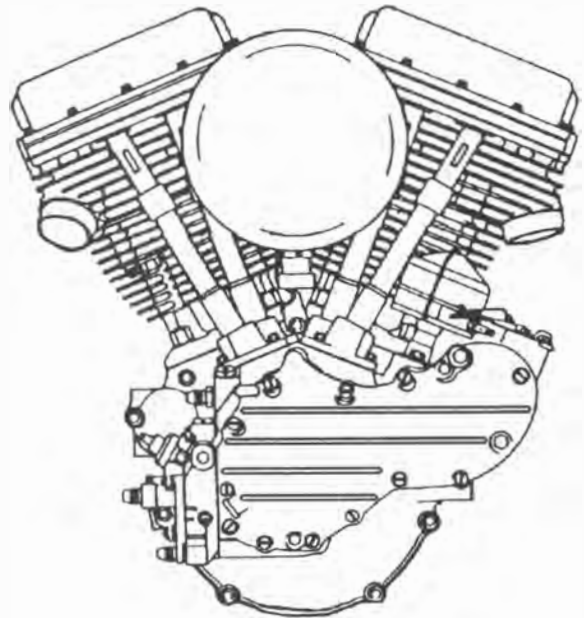



Secretary's Reports

General Chapter Meeting and Annual Holiday Gathering 12/5/04

The annual Yankee Chapter Christmas party was held at the Oxford, MA VFW on a sunny December day. Many of the members arrived on their bikes, well bundled up and proclaiming it to be a great day for a ride. Everyone brought their specialties and a sumptuous buffet awaited us all.

The chapter meeting was called to order at 12:43 pm by our Director Will Paley. Minutes from last year's meeting were read by Diane Stoyanovich and the Treasurer's report was given by Sandy Gallo.

Chapter advisor Fred Hirsch has moved to California and is living with family there. He recently celebrated his 90th birthday. Fred's new address for anyone who would like to send a card or letter is: Fred Hirsch, 9001 LaVerne Drive, Rancho Cucamonga, CA 91701. There is \$1138 left in the Charitable Fund. There was a motion to send \$300 to Fred for appreciation of past support and moving expenses. It was seconded and passed. Yankee Ron Scanterbury, Fred's longtime friend, had taken much time assisting Fred with his move, during which time his own home in Florida was completely destroyed by a hurricane. Sandy moved that we use some of the Charitable Funds and send \$500 to Ron to help rebuild. Jessie seconded the motion and all were in favor.

Will gave the president's report and stated that his job has not been so hard, as everyone has been willing to assist with running events and chapter business. He would like to see more members be able to take a turn at being on the board of directors.

We want to extend a big thank you to Barbara Salisbury for coordinating with the U.S.

Post Office for our Hebron Commemorative Cancellation Stamp. And a thank you to both Barbara and Critter for coordinating the Autumn meet in Sterling.

The National Road Run planning is going well. The hotel has been booked, the banquet is planned. We have road captains and routes organized and an ad has been placed in the national magazine. Door prizes were discussed and Jessie stated that there are a few items left from the Hebron meet that can be used. She also is taking care of having t-shirts printed for the run and basic Yankee Chapter t-shirts printed to sell at Hebron and Sterling. Members of the Yankee Chapter will have the first opportunity for reservations for rooms at the Quality Inn in Lenox, MA. Fees are \$55 per night double room. You will need to reserve rooms directly with the inn. (413-637-4244).

It was noted that on the 2005 National calendar the listings were for a National Road Run on June 19-22 and a National Meet July 30-31 at Hebron. The Hebron meet will actually be a Chapter Meet. Charlie will find out the cost of a full page ad in the national magazine for the Chapter Meet. Charlie will have ads ready for the Hebron Meet and the Road Run. The Hebron Meet runs very smoothly with everyone pitching in to get things done.

Sandy would like to stand down as the membership chairperson. She would be willing to train the new chairperson. Having access to Microsoft Excel program would be quite helpful.

Marty Hansen reported that Nate Sheldon is in a nursing home at this time. A card and get well wishes will be sent to him on behalf of the Yankee Chapter. (Sadly just prior to Christmas Mr. Sheldon passed away. A sympathy card was sent to his son Orville from the chapter).

The board of directors will meet January 16, 2005. There was no further business brought up and the meeting was adjourned at 1:15pm. Everyone enjoyed the holiday buffet and catching up with old and new friends.

Respectfully submitted

Diane

Board of Directors Meeting 1/16/05

The Board of Directors meeting was held on January 16, 2005. The meeting was called to order by Director Will Paley at 12:10 pm. In attendance were Will Paley, Diane Stoyanovich, Stu Stoyanovich, Barbara Salisbury, Don (Crittter) Salisbury, Charlie Gallo, Sandy Gallo, Phil Guiles, Phil Mathews, Randy Walker, Andrew LaRoche, Jessie Aikman, Steve Ciccalone and Dan Margolien.

Agendas were passed out and reviewed. Steve made a motion to dispense with the reading of last year's minutes; this was seconded and passed. Continuing with old business, the Treasurer's report was read by Sandy and copies were made available to anyone who wanted one. With regards to the membership chairperson, Phil Mathews has agreed to take on this position. Sandy will assist him with getting started. Jessie mentioned that we were hosting two events this year with the National Road Run and the Chapter meet in Hebron. She asked if we are still going to have the Sterling meet. There was no discussion at this time, going on to other business. Sandy reported that Fred Hirsch is doing well and passed out cards with his new phone number and address. (Fred D. Hirsch, 9001 LaVerne Drive, Rancho Cucamonga, CA 91701, 909-476-9910).

The Hebron Meet was next on the agenda. Charlie and Sandy brought in several articles about extensive vandalism to the Hebron Fairgrounds earlier this month. Jessie had spoken with an individual from the Lions Club last week. Rebuilding will be done and we should be all set to hold the Yankee Chapter Regional meet on the weekend of July 29-30, 2005. Sandy asked if we could send some money to them from the Charitable Fund. Steve felt that this was a good and valid idea and after some discussion all felt that a donation to the Lions Club would certainly be a gesture of goodwill. Andy made a motion to send a \$500 donation to the Lions Club. The motion was passed with all in favor. A motion was made to transfer enough funds into the charitable account to cover the \$500 and to close out the Charitable Fund Ac-

count. The motion was passed with seven in favor and two votes opposed.

During the discussion of charitable funds, Charlie shared an article about a Vietnam Vets Motorcycle Club that adopted a squad of troops in Iraq and put together packages for those troops. As an organization we are not going to contribute (as funds are exhausted) but certainly individually we should take care and fund such projects as are meaningful to each of us.

Discussion turned to the Hebron Meet banquet. In the past, as a regional meet, the banquet was on a smaller scale, so planning should be for 40-50 people. Sandy will contact the Sportsmans' Club to see what can be offered.

Discussion ensued with regard to advertising. How do we want to advertise and run this meet? Steve suggested that we advertise as a Northeast Regional Meet. A motion was made to take a full page ad in the national magazine. A quarter page ad is free and in the past we have just paid the difference for the full page ad. Charlie will talk to Peter Heintz, the advertising manager. Andy had some ideas about advertising for the Hebron meet. In the past Will had been taking care of some of the advertising for this event and certainly would appreciate some assistance. Charlie has always taken care of the advertising in the national magazine. Sandy nominated Andy to be Publicity chairperson. There are many places that we could advertise for free and newspapers are always looking for copy. It's a good idea to get out a press release to area newspapers just prior to the event. As far as vending goes: as per AMCA rules, vendors need to be members, so ads should reflect this. Ads should include the fact that the vending fee is \$25 for members and \$55 for nonmembers which includes membership to the AMCA. Also the ad should state that vending is limited to parts 35 years and older and/or antique motorcycle related items. Ads should also refer people to the web site. Any vending issues should be referred to Steve.

Next to be discussed for this meet was judging and trophies. Charlie moved that we order 10 trophies inscribed, "Winner - Yankee

Chapter Regional Meet 2005". The motion was passed. Jessie will order the trophies. A motion to print t-shirts with the chapter logo for this year's Hebron and Sterling meets was made and approved. Charlie will get the artwork to Jessie and she will order shirts. Members would like to have long sleeve henleys and possibly pocket t-shirts printed this year. Next on the agenda was the Yankee Chapter National Road Run in the Berkshires. There are two motels available. The host motel is the Econolodge (same motel, new name) in Lenox, MA, with a room rate of \$55 per night. The other motel is the Days Inn with a rate of \$75 per night. Will has been in contact with the caterer. He had menu ideas for both sitdown meals and buffet meals. Members felt the buffet would be the better plan. Will will make final arrangements with the caterer. Jessie will contact both the motel and the tent company with regards to having a tent set up for registration and inclement weather. Jessie had several catalogs for us to look through with items to personalize for the registration packets. Barbara will look into availability of a postage stamp with an antique motorcycle for either inclusion in packets or as a door prize. Ideas were to have a canvas bag or duffle bag with logo to hold registration packet items. Items for the packets will be an embroidered hat, license plate medalion, kick stand puck (Jessie will call V-Twin) and pin. Discussion had on what to provide for the packet, as well as the costs for the run which would include fees to several stops on the routes. Mount Greylock charges a \$2 parking fee, Hemmings is free and we will make a donation to the museum at the Aerodrome. There are other places of interest that will be listed but are optional stops. The admission fees will not be covered. We discussed whether or not to have a photographer at registration but decided not to. We all need to solicit for door prizes for the banquet. Road captains will be Tim Gottier, Andy Bagas and Will Paley. Several people have offered use of truck and trailer for rider support. Will and Phil will send out a confirmation letter and release of liability to riders upon receipt of registration. Release will be signed

and collected the day of registration.

We all had a great time at the annual Christmas party and the new location was very accommodating. Sandy wanted to know if we want to reserve and put down a deposit for the Oxford VFW for December 4, 2005. Everyone agreed to this. Randy will check to see if we could also have our board meeting there.

Steve brought us up to date on what is happening with continued discussion of having a joint meet with several other chapters. Will mentioned the Goshen Agricultural Fairground as a possible site if this were to take place, but at this time we will keep our usual dates of August 4, 5, and 6 for the 2006 national meet at Hebron.

Charlie thanked both Diane Stoyanovich and John Smedes for their photographs of this year's events. He was excited about having so much to work with for the Yankee Chatter this year. Keep them coming!

Before closing, Barbara wanted to discuss the Sterling meet for this year. There was some confusion as to whether we had decided to have the meet. In Hebron we decided to have 3 events this year as they all are certainly worthy of our efforts. The Sterling Meet is on the calendar. The Hebron Meet comes together with everyone's assistance and the Salisburys are willing to coordinate the Sterling Meet again this year. Sterling offers a great place to ride and Critter's Mystery Rides are always enjoyable. Barbara mentioned that instead of a pig roast let's focus on the riding. Either keep the meal simple or there are many local places to enjoy a meal and comraderie. There was a motion to have Barbara and Critter get an itinerary together for the Sterling meet to be discussed at Oley.

The board of directors will meet in Oley on Saturday @ 2:30.

The meeting was adjourned.

Enjoy the winter and I look forward to seeing everyone at the 2005 events.

Respectfully Submitted



Diane

Once Upon A Time

By John Yushkevich

Some years ago I visited the New England Air Museum in Windsor Locks. During my visit I noticed a couple of Indians parked between the planes as part of the displays. The nice old Indians (one a four and one a twin) were a nice accent to the beautifully restored planes and aeronautical engines. This spurred me to thinking about my own gem, a 1926 Henderson DeLuxe, home in my garage and how I might somehow contribute to the enjoyment of the many passing patrons of this fine display. It was during this visit that I met the curator of the New England Air Museum, Mike Speciale, and asked him if he took in displays on loan. He said they did and the rest is history.

I solicited (bribed) my friend, Richard Megson, into helping. A date was set and the DeLuxe was delivered with the use of Richard's

truck.

The DeLuxe ended up being a good fit into the museum. In fact, it's the fourth Henderson DeLuxe engine on display there. No surprise to those who are in the know, Henderson engines were used quite extensively in aeronautics. The transmissions were cut off and air props were bolted directly to the crankshaft. Modifications were made for increased cooling and oil capacity and distribution. Two of the engines on display are Heath conversions. One is engine and prop alone on a engine stand and the other is in a complete plane. The third engine is in a 1938 test stand which was used by Sikorsky to test their helicopter blades during the infancy of helicopter development. For those who would like to see the air museum, it's open daily from 10:00AM till 5:00PM. Tickets are on sale till 4:30PM. They are located at 36 Perimeter Rd., Windsor Locks, CT and their phone number is 860-623-3305. For those who are going to visit to see my DeLuxe, HURRY. I don't think I can go too long without riding it.

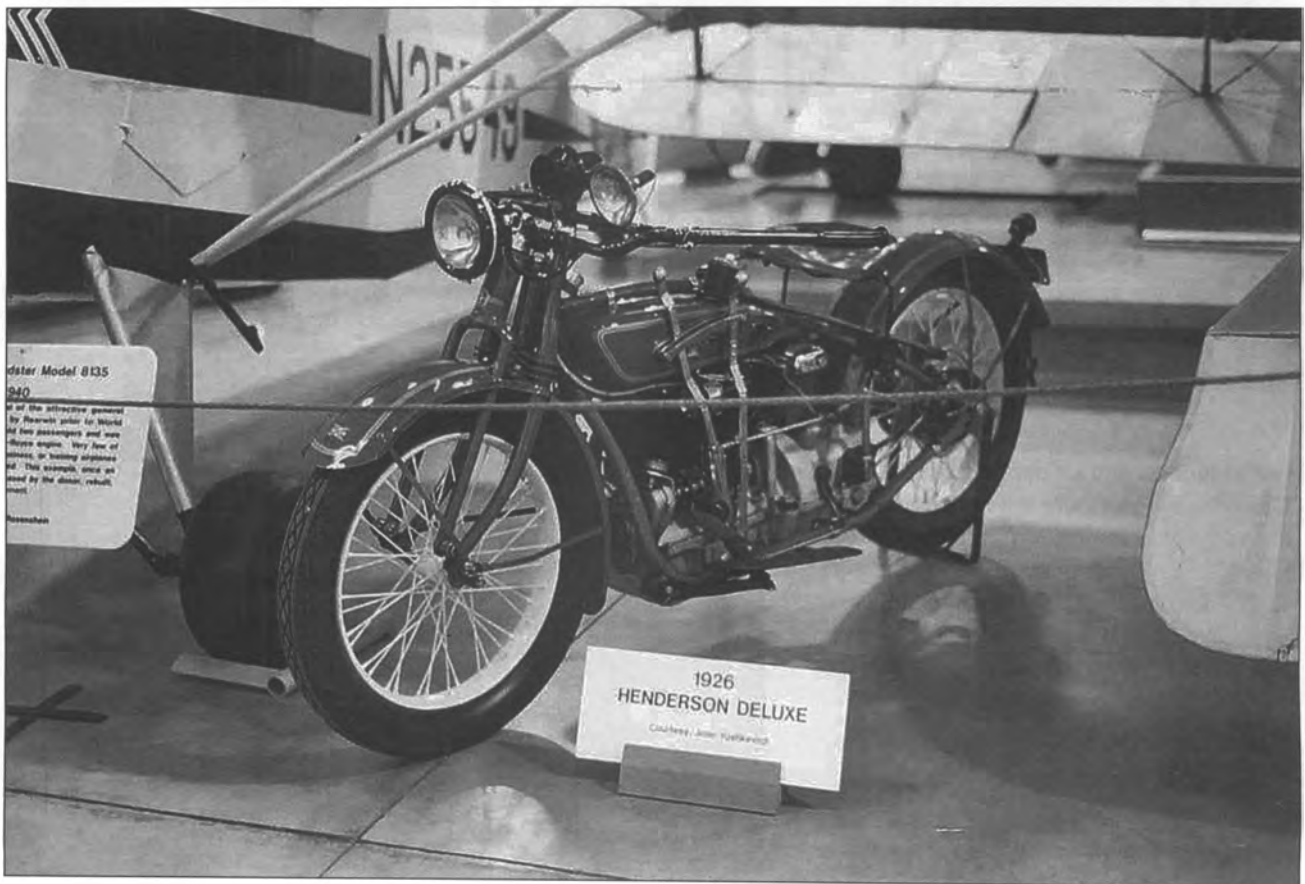

YANKEES

Out And About

Phil Guiles is ready to head out on the road run at the Yankee National Meet in Hebron on July 31, 2004



E. Shapiro Photo

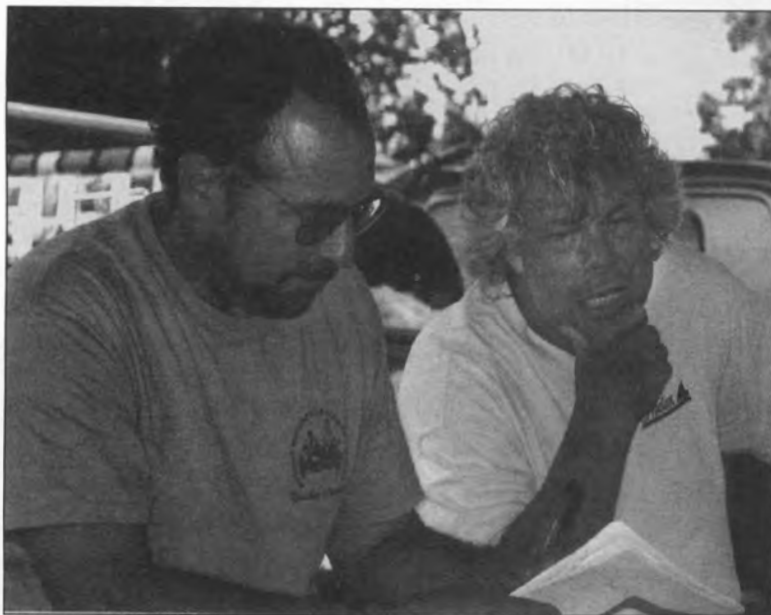

Will Paley and Robin Gazza go over some paperwork at the Yankee National Meet in Hebron.

Diane Stoyanovich Photo

Diane Stoyanovich Photo

Gary Lamothe and Critter Salisbury give Chardonny Pete some last minute instructions before he goes for a ride around the Sterling Park Campgrounds in 2003.

Gary - There's a big rock up on the hill so make sure you don't hit it.

Pete - Got it ! Big rock . . hill . . hit it . . OK!

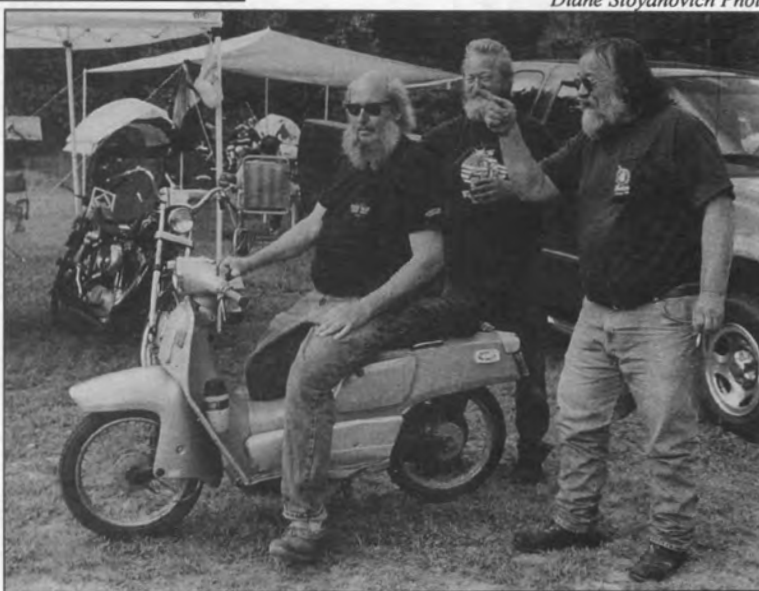

The Yankee Chapter of the AMCA sponsors a

Northeast Regional Swap Meet and Bike Show

Hebron Lions Club Fairgrounds
Hebron, Connecticut
Friday & Saturday
July 29 & 30, 2005



"Ride 'Em, Don't Hide 'Em"

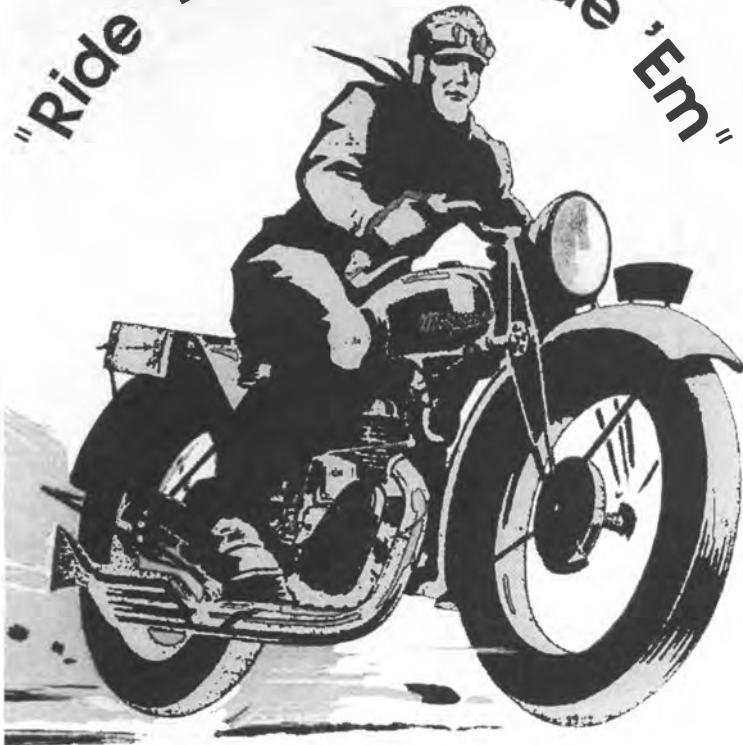

There will be a Saturday road run through scenic Eastern Connecticut. Approximately 50 miles. Bring your bikes and ride 'em.

Camping on grounds for AMCA members and guests. Must show valid AMCA card to camp or vend.

Special Vending Fee:
AMCA Members - \$25.

This will be a Regional Meet. NO AMCA sanctioned judging will be available

Judging for Regional trophies at 4:00 PM Saturday.

Questions, visit:
www.yankeechapter.org
or contact:
Will Paley

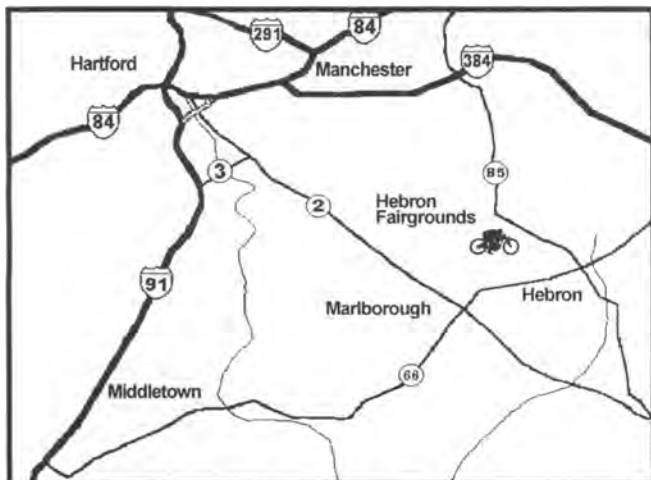

Special Competitions For Chapter Members Only

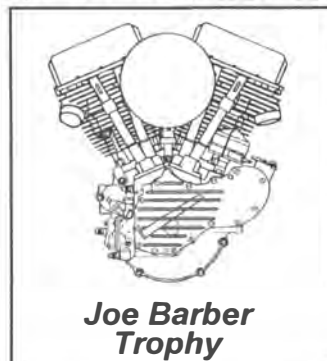

Bring your Panhead to compete for the Joe Barber Trophy



Bring your antique machine and compete for the Giles Adams Award.

YANKEE CHAPTER NATIONAL ROAD RUN

June 19 - 22, 2005

Our road run will be headquartered at The Econolodge (formerly the County Inn) in Lenox, MA (at favorable off-season rates) in the heart of the beautiful Berkshire Mountains. Registration is on Sunday, June 19, with a rider's meeting and dinner that evening. Rides are on Monday, Tuesday and Wednesday with planned visits to Hemmings Motor News, Mount Greylock and Rhinebeck Aerodrome. We will close with a banquet on Wednesday evening.

Berkshire Mountains Road Run



Registration Form

Rider's Name _____ Date of Birth _____

Passenger's Name _____ Date of Birth _____

Rider's Address _____

City _____ State _____ Zip _____

Phone () _____ - _____ AMCA # _____ Chapter _____

Year/Make/Model of motorcycle to be ridden (pre-1971 only) _____

Road Run Fees

\$120 Per motorcycle and rider (includes rider's meeting dinner and banquet) \$ _____

\$ 25 Additional Sunday dinner ticket \$ _____

\$ 30 Additional Wednesday banquet ticket \$ _____

\$ 15 Commemorative T-shirt \$ _____

Number of each size: S ___ M ___ L ___ XL ___ XXL ___ XXXL ___ \$ _____

Total Amount Enclosed \$ _____

Please make checks payable to:

AMCA -Yankee Chapter

Send completed form with payment to:

Sandra Gallo



For more information visit:

www.yankeechapter.org

or contact: Will Paley

Calendar

May 8	Cherry Hill Swap Meet Brooklyn, CT (860) 974-3444 Sponsor: Yankee Jim Ashwell	August 21	Stafford Swap Meet Stafford Springs, CT (860) 875-7768
May 15	Big Sandbar Chapter Meet Fireman's Memorial Park Ridge, Long Island, NY (631) 924-8167	September 4	Vintage Motorcycle Meet Owls Head Transportation Museum Owls Head, ME (207) 594-4418
May 21 - 22	Empire Chapter Meet Dutchess County Fairgrounds Rhinebeck, NY (607) 539-6468	September 9 - 11	Yankee Chapter Meet Sterling, CT (860) 564-8481
June 5	Vintage Motorcycle Days Biker Boutique and Cafe Bridgewater, MA (508) 279-2700 Andy Bagas suggests this event	September 10	The 101 Association Road Run Torrington, CT (508) 867-8097
June 10 - 12	Colonial National Meet Harmony, NJ	September 25	"By Land and By Sea" Mystic Seaport Mystic, CT Pre-registration required (888) SEAPORT
June 19 - 22	Yankee National Road Run Berkshire Mountains Lenox, MA	Sept. 30 - October 1	Chesapeake National Meet Jefferson, PA
June 26	Stafford Swap Meet Stafford Springs, CT (860) 875-7768	October 1	Yankee Steam-Up New England Wireless and Steam Museum East Greenwich, RI (401) 885-0545
July 15 - 16	Pioneer Valley Rally Chester, MA	October 9	CMRA Toy Run East Hartford Elks East Hartford, CT (860) 588-6666
July 17	Indian Day Springfield, MA (413) 737-2624	October 16	Cherry Hill Swap Meet Brooklyn, CT (860) 974-3444 Sponsor: Yankee Jim Ashwell
July 29 - 30	Yankee Chapter's Northeast Regional Meet Hebron, CT	October 23	Stafford Swap Meet Stafford Springs, CT (860) 875-7768
August 19 - 20	Empire National Meet Brookfield, NY	December 4	Yankee Chapter Christmas Party

AMCA sponsored events are listed in bold print. All other events are listed as a public service.

This listing is not meant to be all-inclusive. It consists of events that have been brought to the attention of the editor.

If you have an event that you would like to have listed, please send the information to the editor

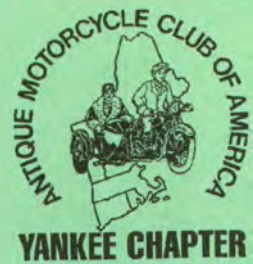

Charles Gallo

FIRST CLASS MAIL

